

# IFBB SET-UP SHEET

NAME: \_\_\_\_\_  
 DATE: \_\_\_\_\_  
 TRACK: \_\_\_\_\_  
 EVENT: \_\_\_\_\_

TRACK			
TRACK SIZE	<input type="checkbox"/> SMALL	<input type="checkbox"/> MEDIUM	<input type="checkbox"/> LARGE
GRIP LEVEL	<input type="checkbox"/> LOW	<input type="checkbox"/> MEDIUM	<input type="checkbox"/> HIGH
TRACK CONDITION	<input type="checkbox"/> SMOOTH	<input type="checkbox"/> GROOVED	<input type="checkbox"/> BUMPY
	<input type="checkbox"/> WET	<input type="checkbox"/> DUSTY	<input type="checkbox"/> LOAMY

COMMENTS

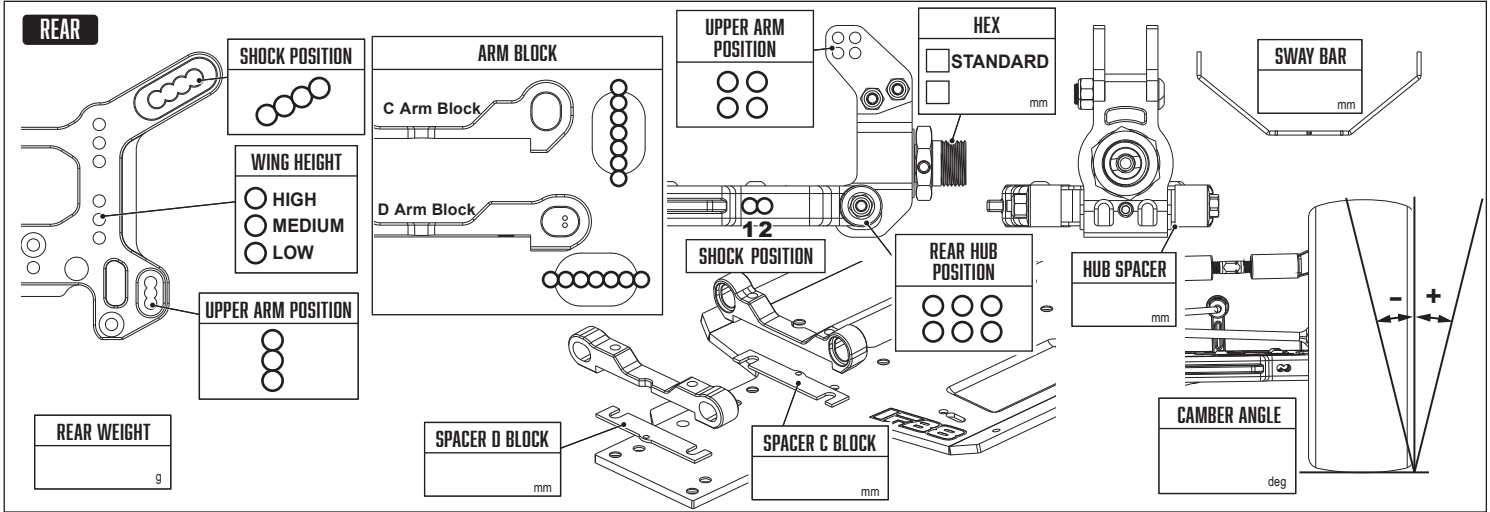
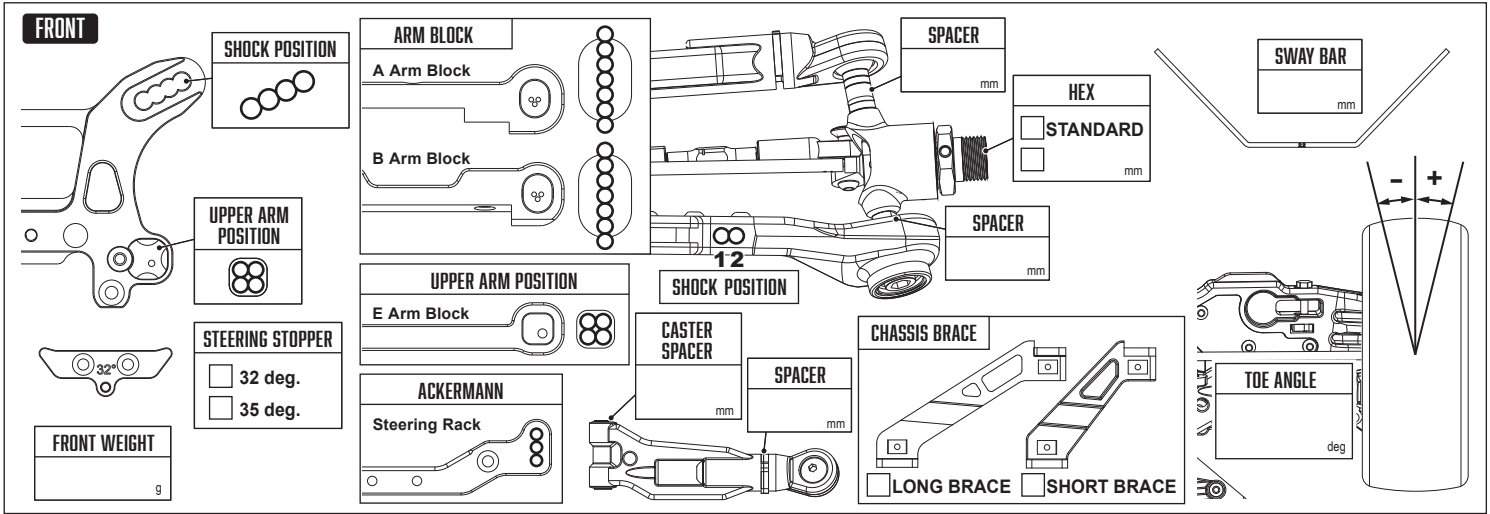

FRONT	SHOCKS	REAR
	OIL	
	SPRING	
	PISTON HOLES	
	MEMBRANE	
	EMULSION	
NOTES:		

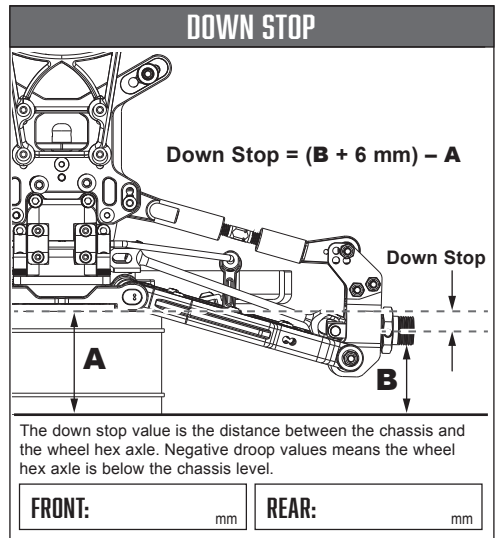
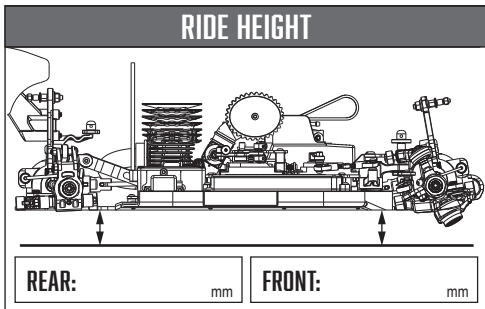

FRONT	DIFFS OIL GRADE	REAR
	CENTER	
NOTES:		

CLUTCH & GEARING	
SPUR GEAR:	BELL:
SHOES:	
SPRING:	
NOTES:	

ENGINE
TYPE:
PIPE:
MANIFOLD:
PLUG:
RESTRICTOR:
FUEL:

BODY & WING
BODY:
WING:
NOTES:

TIRES
TIRE:
INSERT:
WHEEL:
NOTES: